



## Wallace Mighty-Mite Crane

For less demanding applications, Wallace offers Mighty-Mite Cranes with 1/4 and 1/2 ton capacities. They are ideal for home/automotive, office and light industrial use. Unlike most workstations, Mighty-Mite stands on its own frame. In addition to making simple height and span adjustments, you have the flexibility to straddle your work area allowing even more freedom of movement. Engineered with the same standard of excellence built into every Wallace Crane, the Mighty-Mite is an all steel lightweight portable design. These cranes are mounted on protective rubber pads however 6" flat tread casters are available. Available accessories include manual or powered trolleys and hoists and optional track mounting with V-groove casters.

### Product Features

- I-beam spans from 8' - 15'
- Adjustable span allows inboard or outboard bracing and cantilever configuration overhang limited to 25% of the I-beam length (refer to cantilever chart for counterweight required)
- Self-aligning I-beam - exclusive Wallace I-beam support system aligns off-center loads to avoid crane and trolley distortion
  - I-beam support system slides along the I-beam, enabling leg spacing adjustments and cantilever configurations
- Adjustable legs permit crane height adjustment at approximately 6" increments
  - Raise height to go over equipment, material, etc.
  - Lower height to go under low ceilings, doorways, etc...
- Fixed caster tread
- 2 x 2 steel tubing-lightweight offers durable construction and portable design
- Stands on its own frame with protective rubber pads - optional casters are available
  - Casters equipped with 4-position swivel lock that can position the crane more firmly than a brake
  - Lock "lead" casters and unlock trailing casters to easily move and steer crane
  - Alternate steel V-grooved casters are available for use on angle iron track
- Completely portable - Stress-proof steel pins with locking rings provide quick assembly and disassembly
  - Ideal as a workstation for automotive, home, office, and light industrial use

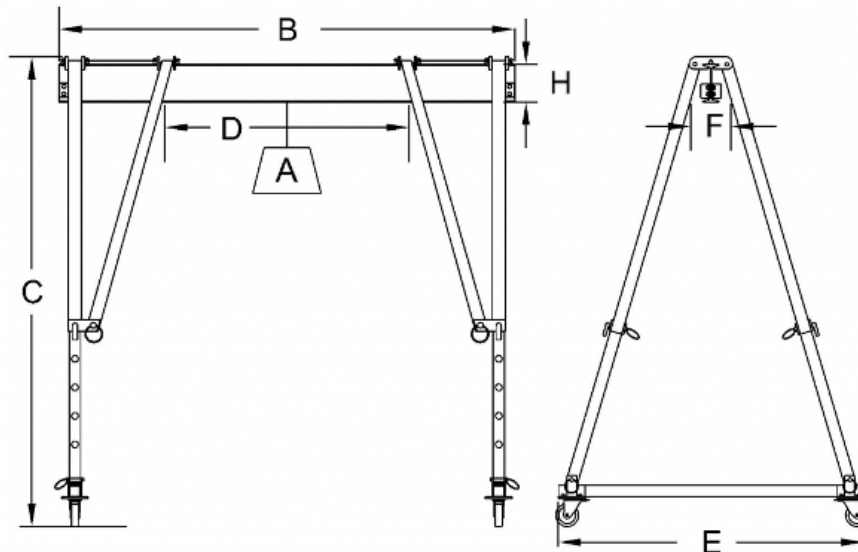

Mighty Mite Dimensional Sketch (Casters Optional) - [Click to enlarge](#)

## Crane Sizes and Model Numbers

A	B		C		D	E	F	H	
Capacity (lbs.)	Span (ft.)	Model Number	Overall Height		Clear Span	Caster Frame Spread	Clearance Between Legs	I-Beam Depth	Weight (lbs.)
			max	min					
500	8	5-08M-8	7'11"	5' 3"	5'2"	5'0"	7"	4"	303
		5-10M-8	9'11"	6'2"	5'2"	6'0"	7"	4"	337
		5-12M-8	12'0"	8'1"	5'2"	6'9"	7"	4"	368
	10	5-08M-10	7'11"	5'3"	7'2"	5'0"	7"	4"	319
		5-10M-10	9'11"	6'2"	7'2"	6'0"	7"	4"	353
		5-12M-10	12'0"	8'1"	7'2"	6'9"	7"	4"	384
	12'	5-08M-12	7'11"	5'3"	9'2"	5'0"	7"	4"	335
		5-10M-12	9'11"	6'2"	9'2"	6'0"	7"	4"	369
		5-10M-12	12'0"	8'1"	9'2"	6'9"	7"	4"	400
1000	8'	10-08M-8	7'11"	5'3"	5'0"	5'0"	8"	6"	349
		10-10M-8	9'11"	6'2"	4'9"	6'0"	8"	6"	383
		10-12M-8	12'0"	8'1"	5'3"	6'9"	8"	6"	414
	10'	10-08M-10	7'11"	5'3"	7'0"	5'0"	8"	6"	374
		10-10M-10	9'11"	6'2"	6'9"	6'0"	8"	6"	408
		10-12M-10	12'0"	8'1"	7'3"	6'9"	8"	6"	439
	12'	10-08M-12	7'11"	5'3"	9'0"	5'0"	8"	6"	399
		10-10M-12	9'11"	6'2"	8'9"	6'0"	8"	6"	433
		10-12M-12	12'0"	8'1"	9'3"	6'9"	8"	6"	464
	15'	10-08M-15	7'11"	5'3"	12'0"	5'0"	8"	6"	437
		10-10M-15	9'11"	6'2"	11'9"	6'0"	8"	6"	471
		10-12M-15	12'0"	8'1"	12'3"	6'9"	8"	6"	502

Cranes are mounted on protective rubber pads. Durable flat-tread or V-groove casters also available.

Note: I-Beams may be cut to custom lengths at no additional charge

## Optional Casters

- **Carton 127-00NB** - 6" Casters
  - When ordering, add "C" to end of crane model number
  - Add 30 lbs. to Shipping Weight
  - Add 7-3/8" to Overall Height Dimensions
- **Carton 116-0000** - 6" V-Groove Casters
  - When ordering, add "V" to beginning of crane model number
  - Add 48 lbs. to Shipping Weight
  - Add 7-1/4" to Overall Height Dimensions without Wallace track
  - Add 7-7/8" to Overall Height Dimensions with Wallace track