



## Wallace 0.5 - 1 Ton Aluminum Thrifty Fixed Height Cranes

The lightweight Thrifty aluminum 0.5- and 1-ton fixed-height gantry crane is one of our most popular product lines weighing in as little as 135 pounds. It offers the greatest clear span of any Wallace gantry crane, and the aluminum design makes it an ideal combination of high lifting and reduced weight. Our corrosion-resistant aluminum cranes have a wide variety of indoor-outdoor, commercial and industrial applications where quick assembly and heavy lifting are required, where there is limited space, or when you need an economical way to lift and move heavy loads inside your facility and traditional cranes just aren't suitable.

Available accessories include manual or powered trolleys and hoists, cable ratchet kits (up to 5 ton capacities) for frequent crane height adjustments, and adjust-a-span kits (available on I-beams 15' or less). Options for track mounting with V-groove caster and motorizing cranes are also available. Check out our accessories page for a full listing of optional accessories.

### Product Features

- Economical alternative to our Tri-Adjustable Crane
- Sturdy aluminum construction is completely portable, lightweight, and corrosion-resistant
- Available in 1,000 – 2,000-lb. capacities
- American Standard I-beam spans from 8' - 15'
- Strong rectangular posts and frames
- Gussets for added strength eliminate the need for brace legs which allows for greater clear span
- Fixed heights range from 9'6" to 9'10" (customizable on request)
- Casters equipped with 4-position swivel lock - when locked 90 degrees with each other, they position more firmly than a brake
  - Lock "lead" casters and unlock trailing casters to easily move and steer crane
  - Alternate steel V-grooved casters are available for use on angle iron track

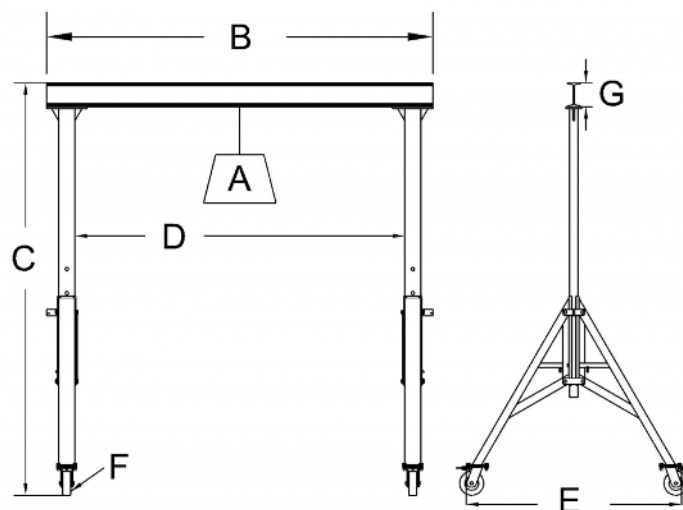

Thrifty Crane Dimensional Sketch - [Click to enlarge](#)

**Crane Sizes and Model Numbers**

<b>A</b>	<b>B</b>		<b>C</b>	<b>D</b>	<b>E</b>	<b>F</b>	<b>G</b>	
<b>Capacity</b>	<b>Span (ft.)</b>	<b>Model Number</b>	<b>Overall Height</b>	<b>Clear Span</b>	<b>Tread</b>	<b>Caster Dia.</b>	<b>I-Beam Depth</b>	<b>Ship Wt.</b>
<b>1/2 Ton</b>	8'	<b>FA19-8AC</b>	9' 6"	6' 10"	4' 6"	6"	6"	135
	10'	<b>FA19-10AC</b>	9' 6"	8' 10"	4' 6"	6"	6"	144
	12'	<b>FA19-12AC</b>	9' 6"	10' 10"	4' 6"	6"	6"	153
	15'	<b>FA19-15AC</b>	9' 8"	13' 10"	4' 6"	6"	8"	198
<b>1 Ton</b>	8'	<b>FA29-8AC</b>	9' 6"	6' 10"	4' 6"	6"	6"	135
	10'	<b>FA29-10AC</b>	9' 8"	8' 10"	4' 6"	6"	8"	164
	12'	<b>FA29-12AC</b>	9' 8"	10' 10"	4' 6"	6"	8"	177
	15'	<b>FA29-15AC</b>	9' 10"	13' 10"	4' 6"	6"	10"	234